

# AI-716 ARTIFICIAL INTELLIGENCE INDUSTRIAL CONTROLLER

## Operation Instruction

*Ver. 8.3*

***(Applicable for accurate controls of temperature, pressure, flow, level, humidity  
etc.)***

## CONTENTS

<b>1. SUMMARY</b> .....	<b>1</b>
1.1    MAIN FEATURES	1
1.2    TECHNICAL SPECIFICATION	3
1.3    ORDERING CODE DEFINITION	6
1.4    REAR TERMINAL LAYOUT AND WIRING	15
<b>2. DISPLAYS AND OPERATIONS</b> .....	<b>20</b>
2.1    FRONT PANEL DESCRIPTION	20
2.2    PARAMETER SETTING FLOW CHART	21
2.3    OPERATION DESCRIPTION	23
2.3.1    Set Value Setting	23
2.3.2    Parameter Setting	23
2.3.3    Setpoint / Output Value Switch	24

2.3.4	Auto Tuning	24
<b>3.</b>	<b>PARAMETERS AND SETTINGS</b> .....	<b>26</b>
3.1	PARAMETER LOCK (LOC) AND FIELD PARAMETERS	26
3.2	THE ENTIRE PARAMETER TABLE	28
3.3	ADDITIONAL REMARKS OF SPECIAL FUNCTIONS	37
3.3.1	Single-phase phase-shift trigger output	37
3.3.2	Alarm blocking at the beginning of power on	37
3.3.3	Communication function	38
3.3.4	Temperature retransmitter / set current output	38

# 1. SUMMARY

## 1.1 Main Features

- Universal thermocouples, RTDs, linear current/voltage signals and user defined input are selectable, integrating non-linear graduation tables, digital calibration and auto zero technology, and achieving accurate and stable measurement.
- Application of advanced artificial intelligence control algorithm with auto tuning function, no overshoot.
- Provided with auto/manual bumpless switch and soft-start function.
- New generation of X3 and X5 current output modules with accuracy 0.2%F.S., improving the precision of control and retransmission.
- Fast communication with sampling rate 12.5 times/ second and minimum control period 0.24 second, able to control quickly change object
- Application of advanced modular structure, conveniently providing plentiful output options, can satisfy various application requirements, and make quick delivery and easy maintenance.

- Friendly and customized operating interface leads to easy learning and simple manipulation. Any parameter can be promoted to immediate operator access in Field Parameter Table or password protected in Full Parameter Table.
- With worldwide power supply of 100-240VAC or 24VDC and various dimensions for user to choose.
- High quality and performance hardware design, using high performance tantalum capacitor or ceramic capacitor. Compared to competing models, it consumes less electricity, experiences less temperature shifting, provides higher stability and reliability, and can work in a wider range of temperature.
- ISO9001 and CE certified, achieving world class level of quality, anti-interference ability and safety. The power and all I/O terminals passed 4KV/5KHz EFT test, and the instrument can work stably under interference.

#### **POINTS FOR ATTENTION**

- Please correctly set parameters according to input / output type and function. Only correctly wired instruments with parameters correctly set can be put into use.

## 1.2 Technical Specification

### ti **Input type: (Any of below specifications can be used selectively in the same instrument)**

Thermocouple: K, S, R, E, J, N, T, B, N, WRe3-WRe25, WRe5-WRe26

Resistance temperature detector: Cu50, Pt100

Linear voltage: 0~5V, 1~5V, 0~1V, 0~100mV, 0~20mV, -5~+5V, -1~+1V, -20~+20mV, etc.

Extended input (install I4 module in MIO) : 0~20mA, 4~20mA or two line transmitter.

Linear resistance: 0~80ohm, 0~400ohm (can measure distant resistance transmission pressure gauge)

Radiation temperature transducer: F2

Extended input: user defined non-linear graduation table and various extended input modules optional

### ti **Instrument Input range**

K(-100~1300°C), S(0~1700°C), R(0~1700°C), T(-200~+390°C), E(0~1000°C), J(0~1200°C),

K(-148~2372°F), S(32~3092°F), R(32~3092°F), T(-328~734°F), E(32~1832°F), J(32~2192°F),

B(600~1800°C), N(0~1300°C), WRe3-WR325(0~2300°C), WRe5-WRe26(0~2300°C),

B(1112~3272°F), N(32~2372°F), WRe3-WR325(32~4172°F), WRe5-WRe26(32~4172°F),

Cu50(-50~+150°C), Pt100(-200~+800°C), Pt100(-100~+300°C),

Cu50(-58~+302°F), Pt100(-328~+1472°F), Pt100(-148~+572°F)

Linear Input: -9990~+30000 units defined by user.

ti **Measurement accuracy** : 0.2%FS ± 0.1°C

ti **Resolution** : 0.1 or 0.01°C for temperature measurement, 1/20000 unit for linear signals, and minimum voltage resolution is 1uV

ti **Temperature drift** : ≤0.02%FS /°C (typical value is 50ppm/°C)

ti **Sampling period** : read A/D converter 12.5 times per second

ti **Response time** : ≤0.5s ( when digital filter parameter FILt=1); ≤3s for 0.01°C measurement

ti **Alarm function** : high limit, low limit, deviation high limit and deviation low limit; with alarm blocking at the beginning of power on.

ti **Control mode:**

On-off control mode (Hysteresis adjustable)

Standard PID with auto tuning

AI PID with auto tuning, adopting Yudian AI algorithm.

ti **Control period** : 0.2~120.0 seconds selectable, and it should be integer times of 0.24 second.

ti **Output mode (modularized)**

**Relay output (NO+NC):** 250VAC/2A or 30VDC/2A

**TRIAC no contact discrete output (NO or NC):** 100~240VAC/0.2A (continuous), 2A (20mS instantaneous, repeat period  $\geq$  5s)

**SSR Voltage output:** 12VDC/30mA (used to drive SSR).

**Thyristor zero crossing trigger output:** can trigger TRIAC of 5~500A, a pair of inverse paralleled SCRs or SCR power module. Single-phase or three-phase trigger is selectable.

**Linear current output:** 0~20mA, 4~20mA (Output voltage  $\geq$  11V, maximum load resistor 500ohm, output precision 0.2%FS)

ti **Electromagnetic compatibility (EMC) :**  $\pm$ 4KV/5KHz according to IEC61000-4-4; 4KV according to IEC61000-4-5.

ti **Isolation withstanding voltage :** between power, relay contact or signal terminal  $\geq$  2300VDC; between isolated electroweak terminals  $\geq$  600VDC

ti **Power supply :** 100~240VAC, -15%, +10% / 50-60Hz; 120~240VDC; or 24VDC/AC, -15%, +10%.

ti **Power consumption:**  $\leq$  6W



- ti **Operating Ambient** : temperature -10~60°C; humidity ≤90%RH
- ti **Front panel dimension**: 96×96mm, 160×80mm, 80×160mm, 48×96mm, 96×48mm, 48×48mm, 72×72mm
- ti **Panel cutout dimension**: 92×92mm, 152×76mm, 76×152mm, 45×92mm, 92×45mm, 45×45mm, 68×68mm
- ti **Depth behind mounting surface**: ≤100mm

### 1.3 Ordering Code Definition

AI series instruments adopt advanced modularized hardware design. There are maximum five module sockets: multi-function input/output (MIO), main output (OUTP), alarm (ALM), auxiliary output (AUX) and communication (COMM). The modules can be purchased together with or separately from the instrument, and can be assembled freely. The input type can be freely set to thermocouple, RTD, or linear current/voltage.

The ordering code of AI-719 series instrument is made up of 8 parts. For example:

AI-716    A    N    X3    L5    N    S4 — 24VDC  
 ①            ②            ③            ④            ⑤            ⑥            ⑦            ⑧

It shows that the model of this instrument is AI-716, front panel dimension is 96×96mm, no module is installed in MIO

(Multi-function I/O) socket, X3 linear current output module is installed in OUTP (main output), L5 (dual relay contact output module) is installed in ALM (alarm), no module is installed in AUX (auxiliary output), a RS485 communication interface with photoelectric isolation is installed in COMM (communication interface), and the power supply of the instrument is 24VDC.

The following is the meanings of the 8 parts:

① **shows the model of the instrument**

**AI-716** Enhanced type controller with measurement accuracy 0.2%F.S. It adopts artificial intelligence control technology, and has the functions of auto/manual bumpless switch, soft-start, and slope control.

② **shows the front panel dimension.**

**A/A2** front panel 96×96mm(width×height), cut out 92×92mm, depth behind mounting surface 100mm. A2 has a light bar with 25 segments and 4 levels of luminosity.

**B** front panel 160×80mm(width×height), cut out 152×76mm, depth behind mounting surface 100mm.

**C/C3** front panel 80×160mm(width×height), cut out 76×152mm, depth behind mounting surface 100mm. C3

has an additional light bar with 50 segments and 2 levels of luminosity.

**D** front panel  $72 \times 72$ mm(width  $\times$  height), cut out  $68 \times 68$ mm, depth behind mounting surface 95mm

**E** front panel  $48 \times 96$ mm(width  $\times$  height), cut out  $45 \times 92$ mm, depth behind mounting surface 100mm

**E5** no front panel, DIN rail mounted. 48 X 96 X110mm (width X height X depth)

**F** front panel  $96 \times 48$ mm(width  $\times$  height), cut out  $92 \times 45$ mm, depth behind mounting surface 100mm

③ **shows the module type of multiple function I/O (MIO). N means none, no module installed.**

**I31** Extends a 0~10V or 2~10V linear voltage input. Provide 24VDC power supply for external transducer.

**I4** 4-20mA/0-20mA analogue input module, has a 24VDC/24mA power supply, and can connect to 2-wire transmitter.

**I7** Extends 5A AC current input (isolated type)

**I51** Extends 5A AC current input (non-isolated type, external should connect a transformer)

**I8** Extends 500V AC voltage input (isolated type)

**V24/V12/V10** Isolated 24V/12V/10V DC voltage output module with maximum current of 50mA, can supply power for external transmitter.

- ④ **shows the module type of main output (OUTP). For control output or SV/PV retransmission.**
- L2** Normal open + normal close relay output module (small volume, capacity: 30VDC/1A, 250VAC/1A)
  - L1/L4** Large capacity normal open relay output module (large volume, Capacity: 30VDC/2A, 250VAC/2A)
  - W1** TRIAC no contact normal open discrete output module (Capacity: 100-240VAC/0.2A, burnt proof)
  - W2** TRIAC no contact normal closed discrete output module (Capacity: 100-240VAC/0.2A, burnt proof)
  - G** SSR voltage output module (DC12VDC/30mA)
  - K1** Single-phase thyristor zero crossing trigger output module (can trigger one loop of a TRIAC or a pair of inverse parallel SCR with current of 5-500A)
  - K3** Three-phase thyristor zero crossing trigger output module (can trigger 3-phase circuit; each loop can trigger TRIAC or a pair of inverse parallel SCR with current of 5-500A)
  - K5** Single-phase thyristor phase-shift trigger output module, suitable for 200~240VAC power.
  - K6** Single-phase thyristor phase-shift trigger output module, suitable for 340~415VAC power.
  - X3** Electric isolated linear current output module, support outputs of 0-20mA and 4-20mA etc, and use internal 12VDC power supply.
  - X5** Electric isolated linear current output module, support outputs of 0-20mA and 4-20mA etc. X5 is equipped

with photoelectric isolated power supply and doesn't interfere with the internal power of the instrument.

⑤ **shows the module type of alarm (ALM). For AL1 and AL2 alarm outputs.**

**L1/L2/L4** Single relay output alarm, support AL1.

**L5** Dual normal open relay output module, support AL1 and AL2.

⑥ **shows the module type of auxiliary output (AUX). For AU1 and AU2 alarms and control auxiliary output.**

**L1/L2/L4** Single relay output alarm, support AU1 alarm or auxiliary output of refrigerating/heating control.

**L5** Dual normal open relay output module, support AU1 and AU2 alarm.

**W1** TRIAC no contact normal open discrete output module (Capacity: 100-240VAC/0.2A, burn proof)

**G** SSR voltage output module (DC12V/30mA time proportional output)

**K1** Single-phase thyristor zero crossing trigger output module (can trigger one loop of a TRIAC or a pair of inverse parallel SCR with current of 5-500A)

**X3** Electric isolated linear current output module, support outputs of 0-20mA and 4-20mA etc, and use internal 12VDC power supply.

**X5** Electric isolated linear current output module, support outputs of 0-20mA and 4-20mA etc. X5 is equipped with photoelectric isolated power supply and doesn't interfere with the internal power of the instrument.

R RS232 communication interface module, use the internal 12VDC power supply.

⑦ **shows the module type of communication (COMM).**

S RS485 communication interface module, use the internal 12VDC power supply.

**S4** RS485 communication interface module. S4 is equipped with photoelectric isolated power supply, and doesn't interfere with the internal power supply of the instrument.

**X3** Electric isolated linear current output module, support outputs of 0-20mA and 4-20mA etc, and use internal 12VDC power supply.

**X5** Electric isolated linear current output module, support outputs of 0-20mA and 4-20mA etc. X5 is equipped with photoelectric isolated power supply and doesn't interfere with the internal power of the instrument.

⑧ **shows the power supply of the instrument.** If left blank, the power of the instrument is 100-240VAC. "24VDC" means the power supply of 24V direct current.

**Module K3:** K3 module will take OUP and MIO two sockets. So if K3 is installed and setpoint switching function is needed, installing I2 module in COMM socket and setting parameter bAud to 1 can realize two setpoints switching function.

**Voltage output module:** The voltage output modules like V24, V10 or V12 are often used for supplying power for external transducer or feedback resistance of transmitter. These modules can be installed in any socket. To standardize the wiring, they are recommended to be installed in the first idle socket in the order of MIO, AUX, and COMM.

**Electric isolation of the modules:** There are a group of 24V and a group 12V power supply built in the instrument and isolated from the main circuit. The 24V power commonly supplies voltage output module, such as V24/V12/V10 (24V/12V/10V voltage output module), I2 (on-off signal input module) and I4 (linear current input module). The 12V power commonly supplies output or communication module. Generally, the relay contact output and TRIAC no contact discrete output are self isolated from the other circuit, no matter whether other modules are installed or not. SSR voltage output does not need to be isolated from input circuit, because SSR itself has isolation function. Therefore, only the electric isolation between the communication interface and the current output should be considered. Those modules, for example, S (RS485 communication interface), R (RS232 communication interface) and X3 (linear current output), all need the 12V power supply. If more than one of the above modules are installed, in order to be electric isolated, only one of them can be module without electric isolation, the other modules should be S4 or X4, which has its own isolated power supply. For example,

if an X module is installed in OOTP (main output) socket, and an S or X module is installed in COMM (communication interface) socket, then OOTP and COMM can not be electric isolated, so S or X should be replaced with S4 or X4.

**No contact switch module:** W1 and W2 are new types of no contact switch modules which apply the advanced technology of “burn proof” and zero crossing conduction. It can replace the relay contact switch. Compared to the relay contact output module, W1 and W2 have longer life and lower interference. They can largely decrease the interference spark of the equipment, and greatly improve the stability and reliability of the system. Since the driver element is TRIAC, it is suitable for controlling 100-240VAC (not for DC power) with current up to 80A. For the current larger than 80A, an intermediate relay is needed. Protection elements are series wound to the output terminals, so it can control continuous current up to 0.2A with maximum allowed instantaneous current 2A.

**Relay Module:** The relay modules are widely used in industrial control. However, they are the only modules with life time limit and volume limit and have much electromagnetic interference. There are four types of relay modules: L1, L2, L4 and L5. For control output, L1 or L4 large capacity module is recommended. L4 is equipped with high performance relay with small volume and large capacity but is expensive. L2 module is small, and both its normal open and normal close terminals have the function of varistor spark absorption, but the



capacity is small. It is suitable for alarm output. L1 and L5 have big volume and big capacity. In the 48mm dimension instrument (for example, D2, E, F and E5), only one of L1 or L5 can be installed. L5 has dual output, can be used to support two loops of alarm, for example, AL1+AL2. If you don't like mechanical switch, you can choose G5 (dual SSR voltage driver) and connect with external SSR instead.

**Calibration:** The instrument applies the technology of automatic zero and digital calibration, and is free of maintenance. If the error exceeds certain range, generally, cleaning and drying the inside of the instrument can fix it. If not, send the instrument back to the factory to examine and repair.

**Warranty and maintenance:** Free repair and maintenance will be given in 36 months since the delivery. In order to get full and correct repair, please write the phenomena and causes of the malfunction of the instrument.

## 1.4 Rear Terminal Layout and Wiring

### Wiring graph for instruments except D and D2 dimension.

Note 1: For linear voltage input, if the range is below 500mV, connect to terminals 19 and 18. 0 ~5V or 1 ~5V signal can be inputted from terminals 17 and 18.

Note 2: 4~20mA signal can be converted to 1~5V signal by a 250 ohm resistor and inputted from terminals 17 and 18. If I4 module is installed in MIO socket, 4~20mA signal can be inputted from terminals 14+ and 15-, and 2-wire transmitter can be inputted from terminals 16+ and 14-.

Note 3: The compensation wires for different

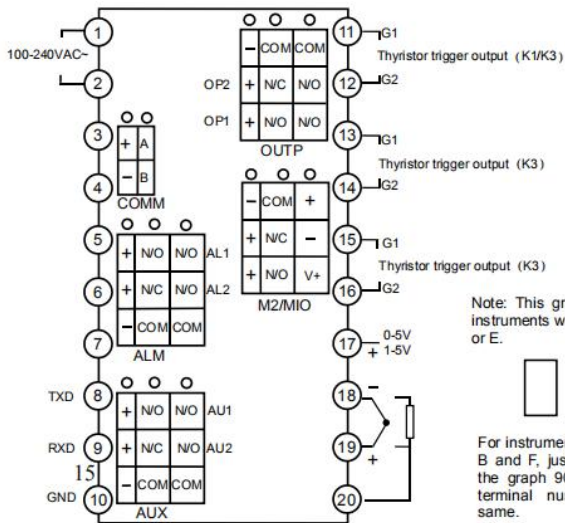

Note: This graph is for upright instruments with dimension A, C or E.

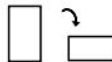

For instruments with dimension B and F, just clockwise rotate the graph 90 degree and the terminal numbers keep the same.

kinds of thermocouple are different, and should be directly connect to the terminals. When the internal auto compensation mode is used, connecting the common wire between the compensation wire and the terminals will cause measurement error.

## Wiring graph of D dimension instruments (72×72mm)

Note 1: Linear voltage signal of range below 500mV should be inputted from terminals 13 and 12, and signal of 0~5V and 1~5V should be inputted from terminals 11 and 12.

Note 2: 4~20mA linear current signal can be converted to 1~5V voltage signal by connecting a 250 ohm resistor and inputted from terminals 11 and 12.

Note 3: S or S4 module can be installed in COMM socket for communication. If relay, TRIAC no contact switch, or SSR driver voltage output module is installed in COMM, it can be used as alarm output. If I2 module is installed in COMM and parameter "bAud" is set to 1, then on-off signal can be inputted, and setpoints SV1 and SV2 can be switched by connecting a switch between terminals 3 and 4.

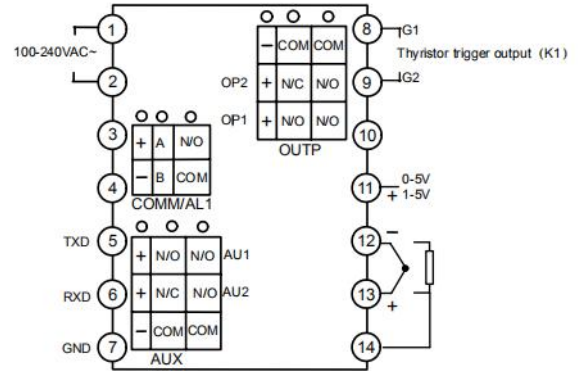

## Wiring graph of thyristor trigger output

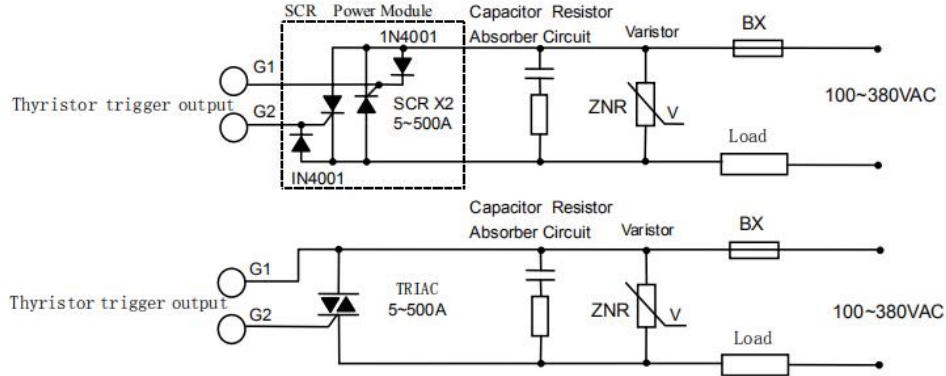

Note 1: According to the voltage and current of load, choose suitable varistor to prevent the thyristor. Capacitor resistor absorber is needed for inductance load or phase-shift trigger output.

Note 2: SCR power module is recommended. A power module includes two SCRs, is similar to the above dashed square.

Note 3: K5 phase-shift trigger module only support 200~240VAC / 50Hz power, and K6 phase-shift trigger module only support 340~415VAC / 50Hz power.

## 2. DISPLAYS AND OPERATIONS

### 2.1 Front Panel Description

- ① Upper display window, displays PV, parameter code, etc.
- ② Lower display window, displays SV, parameter value, or alarm code.
- ③ Setup key, for accessing parameter table and conforming parameter modification.
- ④ Data shift key
- ⑤ Data decrease key, and also run/pause switch
- ⑥ Data increase key, and also stop key
- ⑦ LED indicators. The lighting of MAN means in manual output status. PRG indicator flickering means that the temperature rising speed limit function is working. MIO, OP1, OP2, AL1, AL2, AU1 and AU2 indicate I/O operation of the corresponding module. For example, That the

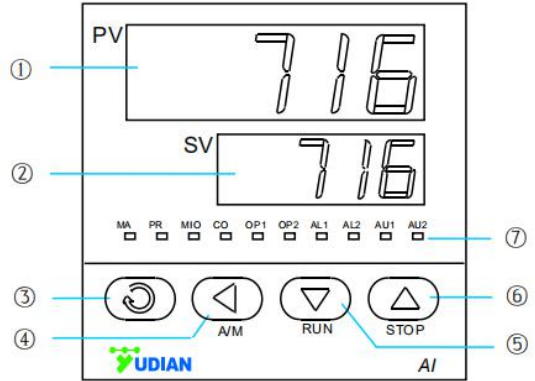

COMM indicator is lighting means that the instrument is communicating with computer.

**Basic display status** : When power on, the upper display window of the instrument shows the process value (PV), and the lower window shows the setpoint (SV). This status is called basic display status. When the input signal is out of the measurable range (for example, the thermocouple or RTD circuit is break, or input specification sets wrong), the upper display window will alternately display “orAL” and the high limit or the low limit of PV, and the instrument will automatically stop output. If the lower display window alternately display “HIAL”, “LoAL”, “HdAL” or “LdAL”, it means high limit alarm, low limit alarm, deviation high alarm, and deviation low alarm happening. The alarm display can also be turned off by setting parameter AdIS to oFF. If “EErr” is displayed, it means internal self-test error, and the instrument should be sent back for repair.

## 2.2 **Parameter Setting Flow Chart**



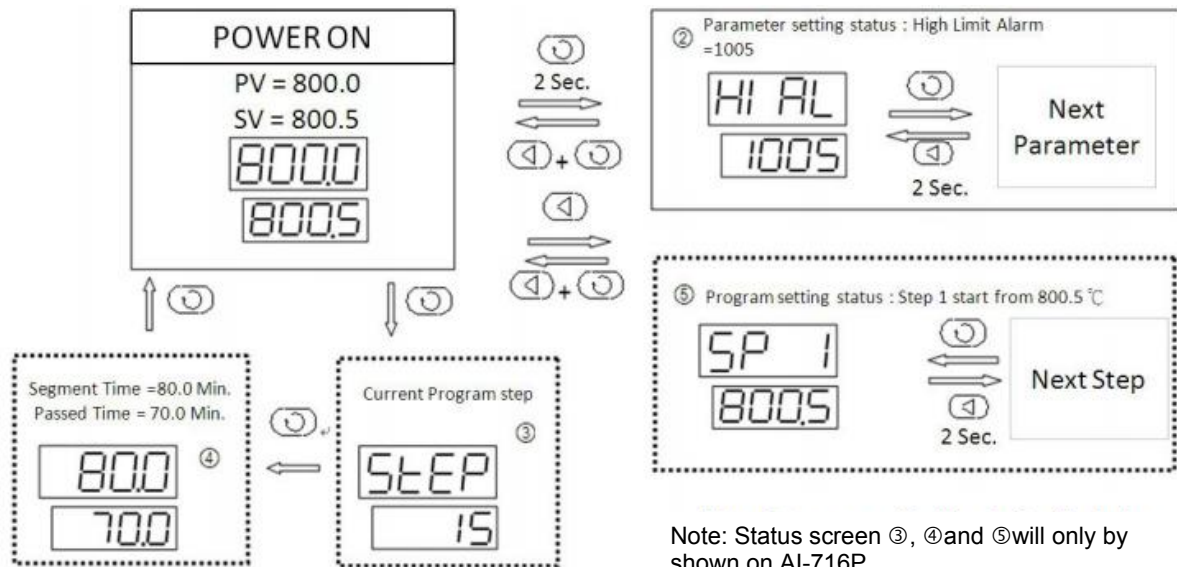

















Note: Status screen ③, ④ and ⑤ will only be shown on AI-716P.



## 2.3 Operation Description

### 2.3.1 Set Value Setting

In basic display status, if the parameter lock "Loc" isn't locked, we can set setpoint (SV) by pressing ,  or . Press  key to decrease the value,  key to increase the value, and  key to move to the digit expected to modify. Keep pressing  or , the speed of decreasing or inscreasing value gets quick. The range of setpoint is between the parameter SPL and SPH.

### 2.3.2 Parameter Setting





In basic display status, press  and hold for about 2 seconds can access Field Parameter Table. Pressing  can go to the next parameter; pressing ,  or  can modify a parameter. Press and hold  can return to the preceding parameter. Press  (don't release) and then press  key simultaneously can escape from the parameter table. The instrument will escape auomatically from the parameter table if no key is pressed within 25 seconds, and the change of the last parameter will not be saved.

In Field Parameter Table, press  till the last field parameter Loc appears. Setting Loc=password and then press  can access System Parameter Table.

### 2.3.3 Setpoint / Output Value Switch

In the basic display status, pressing  can switch lower display window between displaying setpoint and displaying output value.

### 2.3.4 Auto Tuning

When artificial intelligence PID control or standard PID control is chosen (Ctrl=APId or nPID), the PID parameters can be obtained by running auto-tuning. In basic display status, press  for 2 seconds, the "At" parameter will appear. Press  to change the value of "At" from "oFF" to "on", then press  to active the auto-tuning process. During auto tuning, "At" will flash at lower display window and the instrument executes on-off control. After 2 cycles of on-off action, the instrument will obtain the values of PID control parameters. If you want to escape from auto tuning status, press and hold  for about 2 seconds until the "At" parameter appears again. Change "At" from "on" to "oFF", press  to confirm, then the auto tuning process will be cancelled. After satisfying PID parameters are obtained, At is recommended to be "FoFF" which prevents activating auto tuning in basic display status.

**Note 1:** AI-716 instruments apply the advanced artificial intelligence algorithm, which has avoided the overshoot problem of standard PID algorithm, and achieve precise control.

**Note 2:** If the setpoint is different, the parameters obtained from auto-tuning are possibly different. So you'd better set setpoint to an often-used value or middle value first, and then start auto-tuning. For the ovens with good heat preservation, the setpoint can be set to the highest applicable temperature. It is forbidden to change SV during auto tuning. Depending on the system, the auto-tuning time can be from several seconds to several hours.

**Note 3:** Parameter CHYS (on-off differential, control hysteresis) has influence on the accuracy of auto-tuning. Generally, the smaller the value of CHYS, the higher the precision of auto tuning. But the value of CHYS parameter should be large enough to prevent the instrument from error action around setpoint due to the oscillation of input. CHYS is recommended to be 2.0.

**Note 4:** AI series instrument has the function of self-adaptation. It is able to learn the process while working. The control effect at the first run after auto tuning is probably not perfect, but excellent control result will be obtained after a period of time because of self-adaptation.

### 3. PARAMETERS AND SETTINGS

#### 3.1 Parameter Lock (Loc) and Field Parameters

In order to protect important parameters from being modified by mistake, but also offer enough flexibility for field control, parameter lock (Loc) and field parameters are introduced.

The parameters need to be displayed and modified in the work field are called Field Parameters. The set of field parameters is a subset of the whole parameter set, and can be freely chosen by user.

Loc can authorize different security right as below:

Loc=0~1, allowed to modify field parameters and setpoint, and execute auto tuning;

Loc=2, allowed to modify field parameters, but can't modify setpoint.

Loc=3~255: can only modify "Loc"

Setting Loc=PASd (Password, a number between 256 and 9999. The initial value is 808) and then pressing  to confirm, can enter the whole parameter table and modify all parameters.

1 to 8 field parameters can be defined by parameters EP1 to EP8. If the number of the field parameters is less than 8, the first idle EP parameter should be set to "nonE". The initial values of EPs and Loc are EP1=HIAL, EP2=LoAL, EP3=HdAL, EP4=LdAL, EP5=nonE, EP6=nonE, EP7=nonE, EP8=nonE and Loc=0.

You can redefine field parameters and Loc to change operation style. For example, you can execute auto tuning from field parameter instead of by pressing  in basic display status, and only take HIAL and HdAL as field parameter. The EP parameters and Loc should be set as below:

EP1=HIAL, EP2=HdAL, EP3=At, EP4=nonE, Loc=0, At=FoFF

### 3.2 The Entire Parameter Table

The parameters can be divided to 8 groups including alarm, control, input, output, communication, system, setpoint and field parameter definition. They are listed as below in sequence:

Code	Name	Description	Setting Range
<b>HIAL</b>	High limit alarm	Alarm on when PV (Process Value) >HIAL; alarm off when PV<HIAL-AHYS Alarm output action can be defined by parameter AOP.	-9990~ +30000 units
<b>LoAL</b>	Low limit alarm	Alarm on when PV<LoAL; alarm off when PV>LoAL+AHYS	
<b>HdAL</b>	Deviation high alarm	Alarm on when PV-SV>HdAL; alarm off when PV-SV<HdAL-AHYS	
<b>LdAL</b>	Deviation low alarm	Alarm on when PV-SV<LdAL; alarm off when PV-SV>LdAL+AHYS HdAL and LdAL can also be used as high limit and low limit alarms when needed. (Refer to the description of parameter AF)	
<b>AHYS</b>	Alarm hysteresis	Avoid frequent alarm on-off action because of the fluctuation of PV	0~2000 units
<b>AdIS</b>	Alarm display	<b>oFF</b> : don't display AdIS in the lower display window when alarming; <b>on</b> : alternately display AdIS in the lower display window when alarming.	oFF on
<b>AOP</b>	Alarm output allocation	From right side to left side, the first, second, third and fourth digit of AOP individually indicate the alarm output terminal of HIAL, LoAL, HdAL, and LdAL. 0 shows no	0~4444

		<p>output. 1,2,3 or 4 indicates alarm outputted to AL1, AL2, AU1 or AU2. For example,</p> <p style="text-align: center;"><b>AOP = 3 3 0 1</b></p> <p style="text-align: center;"><b>LoAL HdAL LoAL HIAL</b></p> <p>It shows that HIAL is sent to AL1, LoAL has no output, HdAL and LdAL are sent to AU1.</p> <p>Note 1: When AUX is used as auxiliary output in bidirectional (heating/refrigerating) control, alarm to AU1 and Au2 won't work.</p> <p>Note 2: Installing L5 dual relay output module in ALM or AUX can implement AL2 or AU2 alarm.</p>	
<b>Ctrl</b>	Control mode	<p><b>onoF</b>: on-off control. For situation not requiring high precision;</p> <p><b>APId</b>: advanced artificial intelligence PID control. Recommended</p> <p><b>nPid</b>: standard PID algorithm with anti-integral-saturation function (no integral when PV-SV &gt; proportional band);</p> <p><b>POP</b>: output PV. The instrument works as a temperature retransmitter.</p> <p><b>SOP</b>: output SV. The instrument works as a set current output.</p>	<p>onoF</p> <p>APId</p> <p>nPid</p> <p>POP</p> <p>SOP</p>
<b>Srun</b>	Run/stop control	<p><b>Frun</b>: the instrument is in control status, and can't stop control by pressing "STOP" key.</p> <p><b>run</b>: the instrument is in control status, and can stop control by pressing "STOP" key for 2 seconds.</p> <p><b>StoP</b>: the instrument is in stop status, and can start control by pressing "RUN/HOLD" key for 2 seconds.</p>	<p>Frun</p> <p>run</p> <p>StoP</p>
<b>Act</b>	Acting method	<b>rE</b> : Reverse acting. Increase in measured variable causes an decrease in the	rE



		<p>output, such as heating control.</p> <p><b>dr</b>: Direct acting. Increase in measured variable causes an increase in the output, such as refrigerating control.</p> <p><b>rEbA</b>: Reverse acting with low limit alarm and deviation low alarm blocking at the beginning of power on.</p> <p><b>drbA</b>: Direct acting with high limit alarm and deviation high alarm blocking at the beginning of power on.</p>	<p>dr</p> <p>rEbA</p> <p>drbA</p>
<b>At</b>	auto tuning	<p><b>oFF</b>: Auto tuning function is disable</p> <p><b>on</b>: Active auto turning function to calculate the values of parameters P, I, d and Ctl. After auto tuning is accomplished, "At" will be automatically changed to oFF.</p> <p><b>FoFF</b>: Auto tuning is disable, and activating auto tuning from basic display status is forbidden.</p>	<p>oFF</p> <p>On</p> <p>FoFF</p>
<b>P</b>	Proportional band	<p>Proportional band in PID and APID control. Instead of percentage of the measurement range, the unit is the same as PV.</p> <p>Generally, optimal P, I, D and Ctl can be obtained by auto tuning. They can also be manually inputted if you already know the correct values.</p>	<p>10~9999</p> <p>units</p>

<b>I</b>	Time of Integral	No integral effect when I=0				0~9999 seconds
<b>d</b>	Time of Derivative	No derivative effect when d=0				0~999.9 seconds
<b>Ctl</b>	Control period	<p>Small value can improve control accuracy.          For SSR, thyristor or linear current output, generally 0.2 to 2 seconds.          For relay output or in a heating/refrigerating dual output control system, generally 15 to 40 seconds, because small value will cause the frequent on-off action of mechanical switch or frequent heating/refrigerating switch, and shorten its service life. Ctl is recommended to be 1/4 – 1/10 of derivative time. (It should be integer times of 0.24 second.)</p> <p>When output type is set to relay (OPt or Aut is set to rELY), Ctl will be limited to more than 3 seconds. Auto tuning will automatically set Ctl to suitable value considering both control precision and mechanical switch longevity.</p>				0.2~ 120.0 seconds
<b>CHYS</b>	Control Hysteresis	<p>CHYS is used for ON/OFF control to avoid frequent ON/OFF action of relay.          For a reverse acting (heating) system, when PV &gt; SV, output turns off; when PV&lt;SV-CHYS, output turns on.          For a direct acting (refrigerating) system, when PV&lt;SV, output turns off; when PV&gt;SV+CHYS, output turns on.</p>				0~2000 units
<b>InP</b>	Input specification Code	<b>InP</b>	<b>Input spec.</b>	<b>InP</b>	<b>Input spec.</b>	0~37
		<b>0</b>	K	<b>20</b>	Cu50	
		<b>1</b>	S	<b>21</b>	Pt100	

			<b>2</b>	R	<b>22</b>	Pt100 (-100~+300.00℃)		
			<b>3</b>	T	<b>26</b>	0~80ohm resistor input		
			<b>4</b>	E	<b>27</b>	0~400ohm resistor input		
			<b>5</b>	J	<b>28</b>	0~20mV voltage input		
			<b>7</b>	N	<b>29</b>	0~100mV voltage input		
			<b>8</b>	WRe3-WRe25	<b>30</b>	0~60mV voltage input		
			<b>9</b>	WRe5-WRe26	<b>31</b>	0~1V voltage input		
			<b>10</b>	extended input specification	<b>32</b>	0.2~1V voltage input		
			<b>12</b>	F2 radiation temperature transducer	<b>33</b>	1~5V voltage input		
			<b>15</b>	4~20mA (installed I4 in MIO)	<b>34</b>	0~5V voltage input		
			<b>16</b>	0~20mA (installed I4 in MIO)	<b>35</b>	-20~+20mV		
			<b>17</b>	K (0~300.00℃)	<b>36</b>	-100~+100mV		
			<b>18</b>	J (0~300.00℃)	<b>37</b>	-5~+5V		
		Note	1: An extended input specification can be defined by user (InP=10). A linear graduation table can be inputted by user or manufacture downloaded. If specified when ordering, an additional input specification, for example, Pt526, WRe520, JPt100 (BA2), G(Cu53), or Square root of 0~5V or 1~5V, can be defined.					The If e32,
<b>dPt</b>	Radix point	Four formats (0, 0.0, 0.00, 0.000) are selectable						0, 0.0,

	position	Note 1: For thermocouples or RTD input, only 0 or 0.0 is selectable, and the internal resolution is 0.1. When S or R thermocouple is used, dPt is recommended to be 0. Note 2: For linear inputs, when the measurement value or related parameter is greater than 9999, the display will automatically change to 00.00 format. So it is recommended to select 0.000 format instead of 0 format when the value may be greater than 9999.	0.00, 0.000
<b>SCL</b>	Signal scale low limit	Define scale low limit of input. It is also the low limit of transmitter output (Ctrl=POP or SOP) and light bar display.	-9990~ +30000 units
<b>SCH</b>	Signal scale high limit	Define scale high limit of input. It is also the high limit of retransmission output (Ctrl=POP or SOP) and light bar display.	
<b>Scb</b>	Input offset	Scb is used to shift input to compensate the error caused by transducer, input signal, or auto cold junction compensation of thermocouple. $PV\_after\_compensation = PV\_before\_compensation + Scb$	-1999~ +4000 units
<b>FILt</b>	PV input filter	The value of FILt will determine the ability of filtering noise. When a large value is set, the measurement input is stabilized but the response speed is slow. Generally, it can be set to 1 to 3. If great interference exists, then you can increase parameter "FILt" gradually to make momentary fluctuation of measured value less than 2 to 5. When the instrument is being metrological verified, "FILt" s can be set to 0 or 1 to shorten the response time.	0~40

<b>OPT</b>	main output type	<p><b>SSr</b>: to output SSr driver voltage or thyristor zero crossing trigger signal. G, K1 or K3 module should be installed. The output power can be adjusted by the on-off time proportion. The period (Ctl) is generally 0.5~4 seconds.</p> <p><b>rELy</b>: for relay contact output or for execution system with mechanical contact switch. To protect the mechanical switch, the output period (Ctl) is limited to 3~120 seconds, and generally is 1/5 to 1/10 of derivative time.</p> <p><b>0-20</b>: 0~20mA linear current output. X3 or X5 module should be installed in OUTP socket.</p> <p><b>4-20</b>: 4~20mA linear current output. X3 or X5 module should be installed in OUTP socket.</p> <p><b>PHA</b>: single-phase phase-shift output. K5 module should be installed in OUTP socket. PHA is only for 50Hz power supply, and doesn't support bidirectional control system.</p>	<p>SSr rELy 0-20 4-20 PHA</p>
<b>OPH</b>	Output upper limit	OPH limits the maximum of OUTP (main output) when PV<OEF. OPH should be greater than OPL.	0~110%
<b>OEF</b>	Work range of OPH	<p>When PV&lt;OEF, the upper limit of OUTP is OPL; when PV&gt;OEF, the upper limit of OUTP is 100%.</p> <p>For example, to avoid that the temperature raises too quickly, under 150℃, a heater can work only under 30% of power, then we can set OEF=150.0 (℃), OPH=30 (%)</p> <p>If soft-start function is active and OPrt is long, then SV should be several tens degree higher than OEF, otherwise OPrt may cause the integral of PID increased wrongly.</p>	-9990~ +30000 units
<b>Addr</b>	Communication address	In the same communication line, different instrument should be set to different address.	0~80

<b>bAud</b>	Baud rate	the range of baud rate is 1200~19200bit/s.	0~19.2k
<b>AF</b>	advanced function	<p>AF is used to select advanced function. The value of AF is calculated as below:  <math>AF = Ax1 + Bx2 + Cx4 + Dx8 + Ex16 + Fx32 + Gx64 + Hx128</math>  A=0, HdAL and LdAL work as deviation high and low limit alarms;  A=1, HdAL and LdAL work as high and low limit alarms, then the instrument can have two groups of high and low limit alarms.  B=0, alarm and control hysteresis work as unilateral hysteresis;  B=1, as bilateral hysteresis.  For instruments with light bar, when C=0, the light bar indicates the output value; when C=1, the light bar indicates the process value.  D=0, Spare  E=0, HIAL and LoAL work as high and low limit alarms;  E=1, HIAL and LoAL work as deviation high and low limit alarms, then the instrument can have two groups of deviation high and low limit alarms.  F=0, normal display mode (precise control), the internal resolution is 10 times of display, but the maximum process value is 3000 for linear input.  F=1, high resolution display mode, for value that may be greater than 3000. The internal resolution is the same as the displayed resolution.  G=0, The increase of the measured value caused by the sensor disconnection allows the upper limit alarm  G=1, The increase in the measured value caused by the sensor disconnection does not allow the upper limit alarm. Note that even the normal upper limit alarm (HIAL) will be delayed for about 30 seconds in this mode.</p>	0~255

		H=0, The instrument communication protocol is AIBUS; H=1, The instrument communication protocol is MODBUS compatible mode. Note: AF=0 is recommended.	
<b>SPL</b>	Low limit of SV	Minimum value that SV is allowed to be.	-9990~ +30000 unit
<b>SPH</b>	Upper limit of SV	Maximum value that SV is allowed to be.	
<b>EP1~ EP8</b>	Field parameter definition	Define 0~8 of the parameters as field parameters.	nonE and all parameter codes

### 3.3 Additional Remarks of Special Functions

#### 3.3.1 Single-phase phase-shift trigger output

When OPT is set to PHA, installing a K5 module in OOTP socket can single-phase phase-shift trigger a TRIAC or 2 inverse parallel SCRs. It can continuously adjust heating power by control the conduction angle of thyristor. With non-linear power adjustment according to the characters of sine wave, it can get ideal control. The trigger adopts self-synchronizing technology, so it can also work even when the power supplies of the instrument and the heater are different. Phase-shift trigger has high interference to the electric power, so user should pay attention to the anti-interference ability of other machines in the system. Now the K5 module can be only used in 50Hz power supply.

#### 3.3.2 Alarm blocking at the beginning of power on

Some unnecessary alarms often occur at the beginning of power on. In a heating system, at the beginning of powers on, its temperature is much lower than the setpoint. If low limit and deviation low limit are set and the alarm condition are satisfied, the instrument should alarm, but there is no problem in the system. Contrarily, in an refrigerating system, the unnecessary high limit or deviation high limit alarm may occur at the beginning of power on. Therefore, AI instruments offer the function of alarm blocking at the beginning of power on. When Act is set to rEbA or drbA, the corresponding low or high alarms are blocked until the alarm condition first clears. If the alarm condition is satisfied



again, the alarm will work.

### 3.3.3 **Communication function**

S or S4 module can be installed at COMM socket to communicate with a computer. The instrument can be controlled by computer. A RS232C/RS485 or USB/RS485 converter can enable a computer connect to AI instruments through RS232 or USB communication port. Every communication port of a computer can connect up to 60 AI instruments, or 80 AI instruments if a repeater is installed. A computer with 2 communication ports can connect to up to 160 instruments. Please note that every instrument connecting to the same communication line should be set to a unique communication address. When number of the instruments is big enough, 2 or more computers can be used and built into a local network.

AIDCS application software, a distributed control system software developed by Yudian, can control and manage 1~160 AI instruments, record the data, generate and print reports. If users want to develop their own distributed control system by themselves, the communication protocol of AI instruments can be free offered. There are already many famous distributed control system software support AI instruments.

### 3.3.4 **Temperature retransmitter / set current output**

Besides AI PID, stand PID control and on-off control, if the output is defined as current output, the instrument can also

retransmit PV (process value) or SV (setpoint) into linear current and output from OUP. The precision of current output is 0.2%FS. The corresponding parameters are set as below:

When Ctrl=POP, PV is retransmitted to linear current, the instrument works as temperature retransmitter. When Ctrl=SOP, SV is transmitted and outputted, and the instrument works as an set current output.

OPt is used to choose output type, generally 4~20mA or 0~20mA output.

Parameter InP, SCL, SCH, and Scb are used for selecting input specification, setting low limit or high limit of PV and adjusting input.

For example, in order to retransmit temperature read from K thermocouple, range 0~400°C, to current 4~20mA, the parameters are set as below: Ctrl=POP, InP=0, SCL=0.0, SCH=400.0, OPt=4-20, and X3 or X5 linear current module is installed in OUP socket. When the temperature is less than or equal to 0°C, the output is 4mA. When the temperature equals to 400°C, the output is 20mA. The upper limit of transmitter output can be high up to 110% of the range, which means when PV is 0~440°C, output current is 4~21.6mA.